

**BILL TO/PCC#** \_\_\_\_\_  
**ADDRESS:** \_\_\_\_\_  
 \_\_\_\_\_

**SHIP TO:** \_\_\_\_\_  
**ADDRESS:** \_\_\_\_\_  
 \_\_\_\_\_  SAME AS BILLING

**CLINICIAN:** \_\_\_\_\_  
**CELL #:** \_\_\_\_\_

**PATIENT ID:** \_\_\_\_\_  **STOCK ONLY**

Click here to email form > [HFN\\_Arizona@Hanger.com](mailto:HFN_Arizona@Hanger.com) **CUSTOMER SERVICE PHONE:** 480-894-1755

@	X-SML (F5730)	@	CM	QTY:
15"	18 1/2" - 20 1/2"	38	47-52	
12"	18" - 20"	30.5	46-51	
9"	17 3/8" - 19 3/8"	24	44-49	
6"	16 1/2" - 18 1/2"	15	42-47	
3"	15" - 17"	8	38-43	

**Shipping**  
 Next Day Air  
 2 Day  
 Ground

@	SML (F5731)	@	CM	QTY:
15"	20 1/2" - 22 1/2"	38	52-57	
12"	20" - 22"	30.5	51-56	
9"	19" - 21"	24	48-53	
6"	16 3/4" - 19 3/4"	15	42-50	
3"	16 1/4" - 18 1/4"	8	41-46	

**Shipping**  
 Next Day Air  
 2 Day  
 Ground

@	MED (F5732)	@	CM	QTY:
15"	21 3/4" - 23 3/4"	38	55-60	
12"	21" - 23"	30.5	53-58	
9"	20" - 22"	24	51-46	
6"	18 3/4" - 20 3/4"	15	48-53	
3"	17" - 19"	8	43-48	

**Shipping**  
 Next Day Air  
 2 Day  
 Ground

@	LRG (F5733)	@	CM	QTY:
15"	25" - 27"	38	64-69	
12"	24" - 26"	30.5	61-66	
9"	22 1/2" - 24 1/2"	24	57-62	
6"	20 3/4" - 22 3/4"	15	53-58	
3"	18 5/8" - 10 5/8"	8	47-52	

**Shipping**  
 Next Day Air  
 2 Day  
 Ground

@	X-LRG (F5734)	@	CM	QTY:
15"	26 5/8" - 28 5/8"	38	68-73	
12"	25 3/4" - 27 3/4"	30.5	65-70	
9"	24" - 26"	24	61-66	
6"	22 1/4" - 24 1/4"	15	57-62	
3"	20" - 22"	8	51-56	

**Shipping**  
 Next Day Air  
 2 Day  
 Ground

**SIZING SPECIFICATIONS (IN/CM)**  
 Measure circumference from distal to proximal

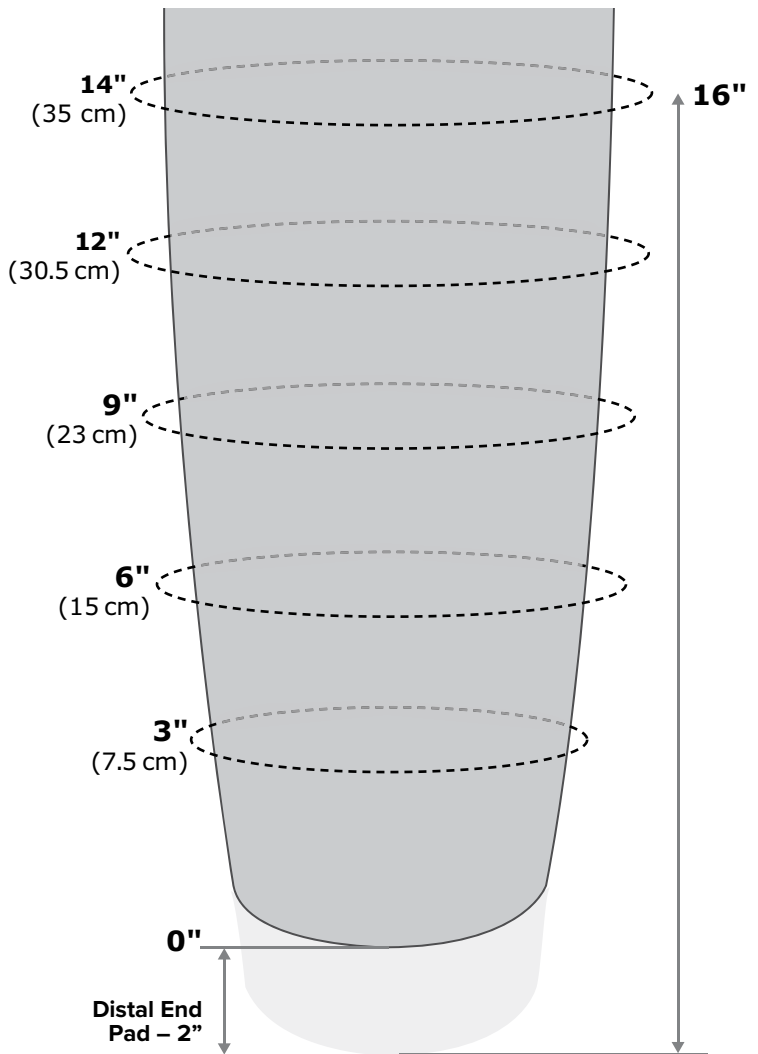

- Total cone height is 16" (40 cm).
- Cut the proximal brim to desired overall length per the instruction sheet enclosed with AmpuShield®.
- Universal customizable Power Belt is included with each device.

**TURNAROUND TIMES**

To review current projected turnaround times for fabrication sites visit the [Daily HFN Capacity Webpage](#).